

Project: \_\_\_\_\_ Type: \_\_\_\_\_ Model No.: \_\_\_\_\_

Remarks: \_\_\_\_\_

**Specifications:**

Lamp Type	Two 5.4W DC T5, wedge-base
Lamp Wattage	120VAC, 60Hz, 0.060A, 6.7W 277VAC, 60Hz, 0.031A, 7.3W
Emergency Operation	90 minutes

**Listings & Certifications:**

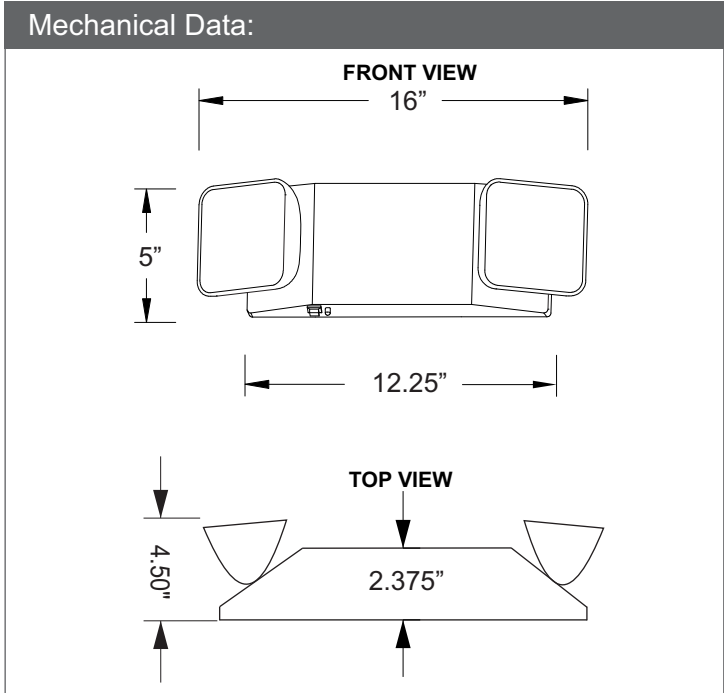

- Standard Features:**
- Push-to-test Switch
  - LED Charge Indicator
  - Maintenance free, 6V sealed lead-acid battery
  - Dual Voltage 120V/277V
  - Specification Grade Design
  - Universal Mount
  - Fully adjustable glare free lighting heads
  - Universal mounting pattern knockout in backplate for J-box mounting
  - Automatic Low Voltage Disconnect (LVD)
  - Damp Location Listed

**Ordering Information:**

Base Model No.	Case Color	Options
FHEM11	W - White	SD - Self Diagnostic
		H - High Lumen Reflector
	B - Black	RC - Remote Capable

Build part number by adding Base Model No., one of each Case Color, and desired options code(s).  
 Example: FHEM11-W-SD

This product does not meet CEC Title 20 Code of Regulations. Fulham extends a limited warranty only to the original purchaser or to the first user for a period of **5 years (excluding lamps)** from the date of manufacture as indicated by the date code stamped on each product and when properly installed and operated under normal conditions of use, including proper care and charging of batteries.

For additional warranty guideline, please refer to our complete product catalog or call customer service at **1-323-779-2980**. DUE TO A PROGRAM OF CONTINUOUS IMPROVEMENT, FULHAM CO., INC RESERVES THE RIGHT TO MAKE ANY VARIATION IN DESIGN OR CONSTRUCTION TO THE EQUIPMENT DESCRIBED.

**Address:** 12705 S. Van Ness Ave., Hawthorne, CA 90250 **Website:** www.fulham.com To order this product: **Fax:** 1-323-754-9060 **Email:** order@fulham.com