

1. Features

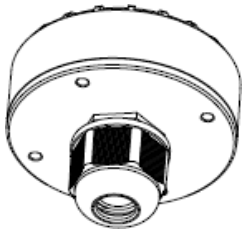

MC079D RC2 A

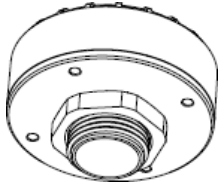

MC079D RC2 B

- 12/24V DC input, for DC systems or LED power supplies with 12/24V DC auxiliary power output
- 0-10V dimming port, 3 or 2 step dimming function
- Newly patent design sensor antenna with two detection mode: high sensitivity detection and interference immunity detection. (suitable for installation environments with many metal reflective surfaces)
- Compact design, special for industrial lamps, sensors can be fixed at the edge or center of UFO.
- 15m maximum installation height, suitable for most warehouses
- Patented remote control, transmitting angle of the remote control is adjustable according to mounting height
- Override function
- Dim+/Dim- to set occupancy light level
- Daylight priority function

2. Parameter

Input	Operating Voltage Range	N/A
	DC Input Voltage	12/24V DC ±1V
	Rated Voltage	12/24V
	No-load Power	N/A
	Stand-by Power	<0.3W
	Surge Test	N/A
	Wiring	MC079D RC2 A fast connector MC079D RC2 B 3 cores cable, wire diameter: 22AWG MC079D RC2 C fast connector
Output	Working Mode	0-10V DC
	Type of Load	N/A
	Load Capacity	N/A
	Current of Load	N/A
	Wiring	MC079D RC2 A fast connector MC079D RC2 B 3 cores cable, wire diameter: 22AWG MC079D RC2 C fast connector
Dim Interface	0-10V Dimming	< 50mA (Non-constant source)
	Synchronous Control	N/A
	High Low-level	N/A
	PWM Control	N/A
Sensor Parameters	Operating Frequency	5.8 GHz ±75 MHz, ISM Band.

	Transmitting power	1mW Max.
	Hold time	5S/30S/1min/3min/5min/10min/20min/30min
	Stand-by DIM Level	10%(1.4-1.6V), 20%(1.9-2.1V), 30%(2.9-3.1V), 50% (4.9-5.1V)
	Stand-by Period	0s/10S/1min/3min/5min/10min/30min/+∞
	Detection Area	25%/50%/75%/100%
	Daylight Sensor	5lux/15Lux/30Lux/50Lux/100lux/150lux/Disable Daylight priority(5lux/15Lux/30Lux/50Lux)/150Lux 100Lux/200Lux 150Lux/300Lux
	Detecting Radius	See detection pattern
	Mounting Height	15m Max
	Detecting Angle	150°(wall mounting) 360°(ceiling mounting)
Wireless Module	Operating Frequency	N/A
	Transmitting power	N/A
	Transmitting distance	N/A
	Modulation mode	N/A
	Number of coding	N/A
Operating Environment	Operating Temperature	-35°C...+70°C
	Storage Temperature	Temperature: -40°C...+80°C; Humidity: 10%-95% (non-condensing)
Certificate Standards	Safety standards	EN60669-2-1, EN60669-1
	EMC standards	EN55015, EN61000-3-2, EN61000-3-3, EN61547
	Environmental Requirement	Compliant to RoHS
	Certificate	CE
Others	Wiring	UL21996,3*22AWG, cable length: 300mm(pending)
	IP Rating	IP20(MC079D RC2 A,MC079D RC2 C),IP65(MC079D RC2 B)
	Protection Class	Class II
	Installation	External mounting, integrated mounting
	Dimension	See dimension
	Package	White paper box
	Net Weight	55g
	Lifetime	50,000h @ Ta Full load
<p>Note</p> <p>1. "N/A" means not available.</p> <p>2. Detection area is effected on volume of motion object and motion speed. The detection area is tested by a 165cm height person and walking speed is 0.5m/s.</p>		

3. Function

1) On/OFF Function (stand-by period be set to "0"s)

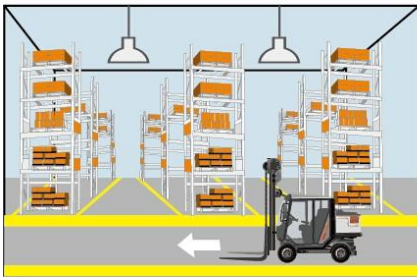

1 With sufficient ambient light, the light will not be switched on even if with motion signal.

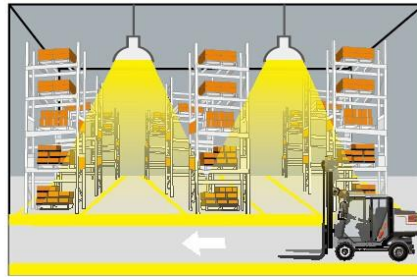

2 With insufficient ambient light, the sensor switches on the light when motion is detected.

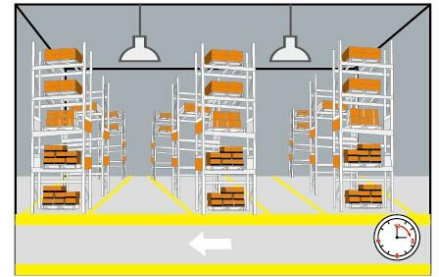

3 After elapse of hold time, the sensor switches off the light when no motion is detected.

2) 2-step dimming function (stand-by period be set to "+∞")

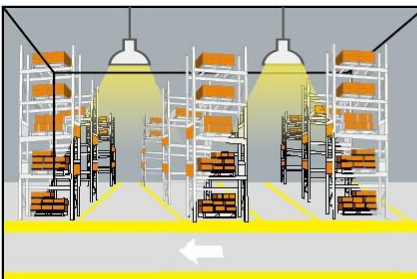

1 If there is no motion detected, the light will be remained at a low light level all the time.

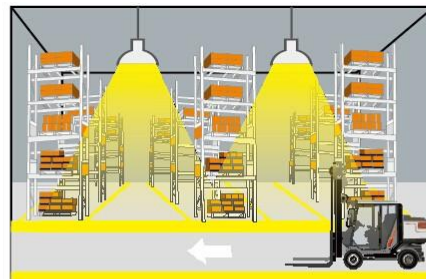

2 When motion is detected, the sensor will switch on the light to 100% brightness

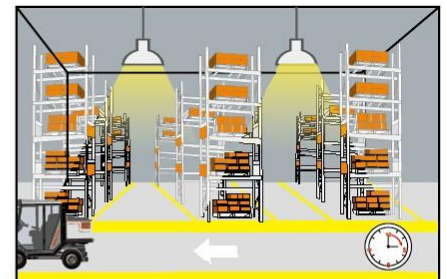

3 After elapse of hold time, the sensor dims the light at the present low light level if no motion is detected.

3) 3-step dimming function (stand-by period be set to "10S/1min/3min/5min/10min/30min")

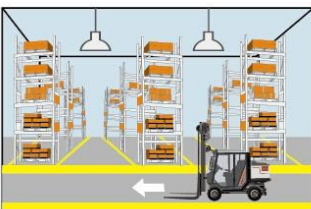

1 With sufficient ambient light, the light will not be switched on even if with motion signal.

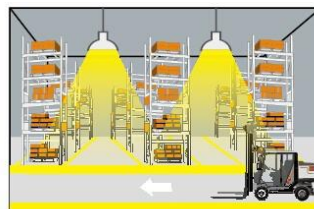

2 With insufficient ambient light, the sensor switches on the light when motion is detected.

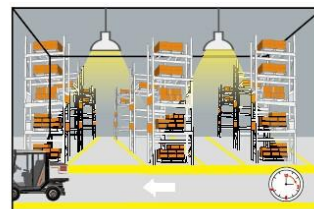

3 After elapse of hold time, the sensor dims the light at a low light level if no new motion is detected.

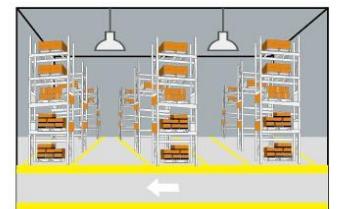

4 After elapse of standby period, the sensor switches off the light if no motion is detected in the detection zone.

4) Daylight priority (stand-by period set to +∞)

4. Dimension (mm)

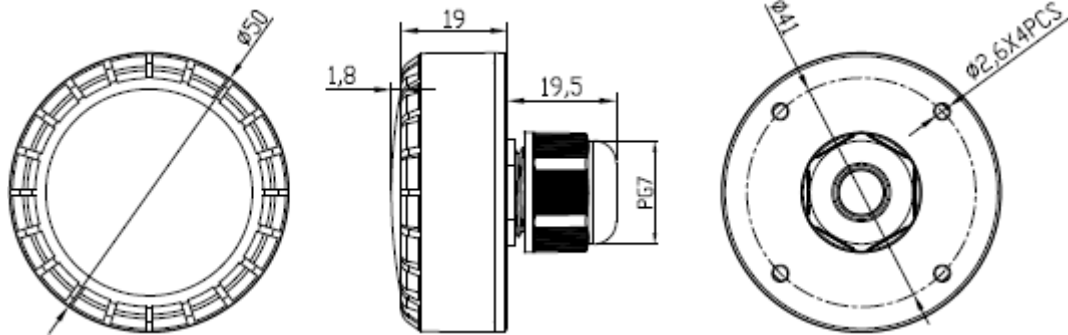

MC079D RC2 A

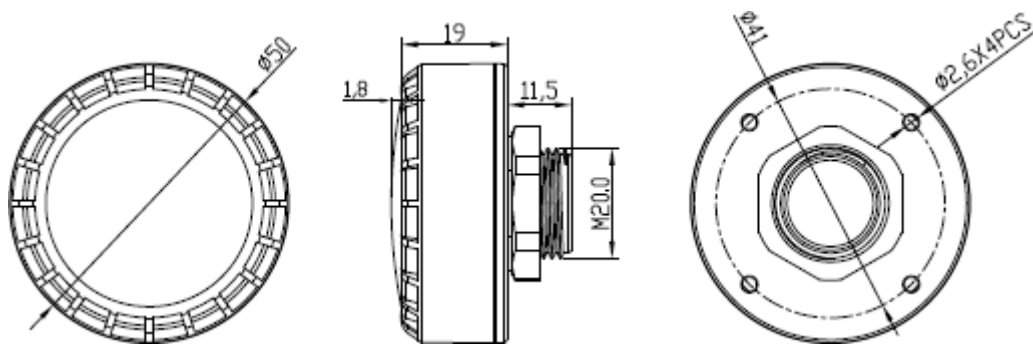

MC079D RC2 B

5. Wiring

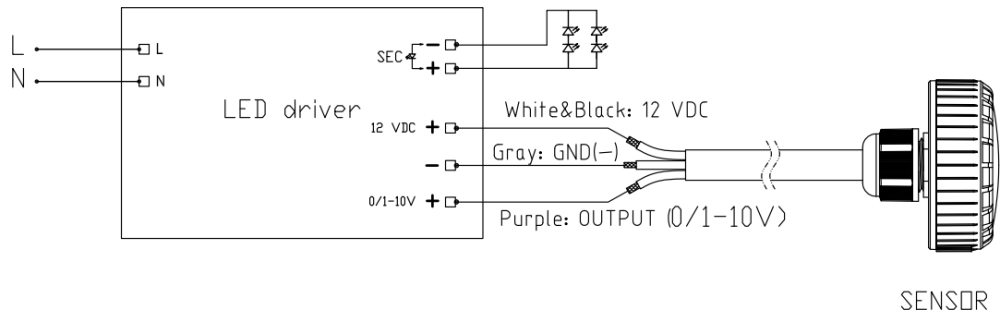

*The sensor is designed to connect one load only. Connect more than one loads may damage the sensor.

6. Structure

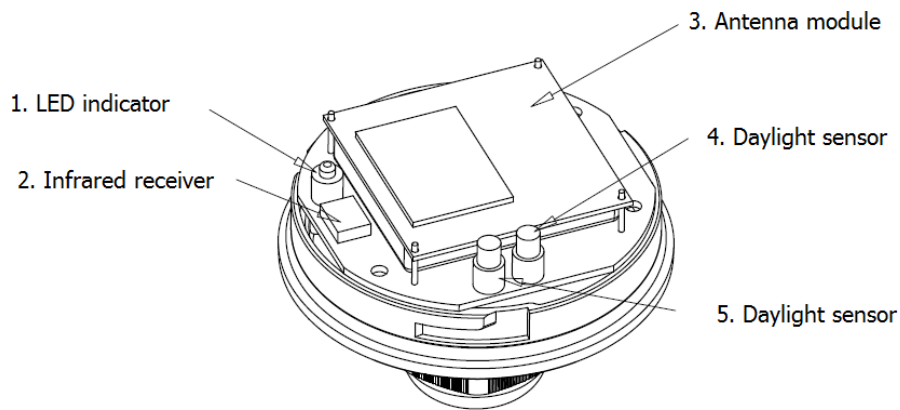

7. Radiation Pattern

Ceiling mounting

Ceiling mounted height: 3m
Sensitivity: 100%/75%/50%/25%

Ceiling mounted height: 12m
Sensitivity: 100%/75%/50%/25%

Ceiling mounted height: 15m (*)
Sensitivity: 100%/75%/50%

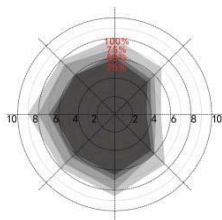

Normal moving (Speed:1m/s)

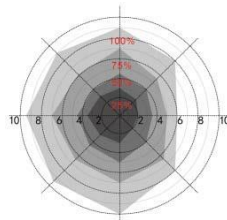

Normal moving (Speed:1m/s)

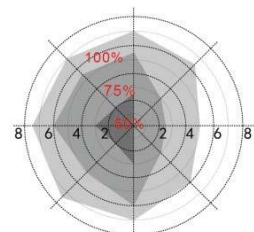

Normal moving (Speed:1m/s)

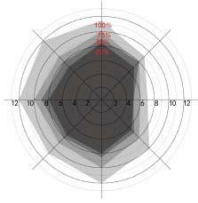

Slow moving (Speed 0.3m/s)

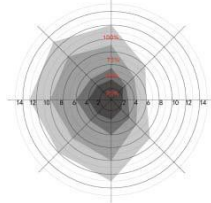

Slow moving (Speed 0.3m/s)

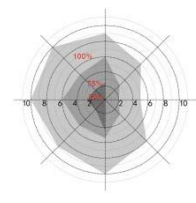

Slow moving (Speed 0.3m/s)

*Only 100%/75%/50% detection sensitivity is workable when installed at 15m mounting height. 25% sensitivity is not able to detect motion signal.

Wall mounting

Horizon mounted height: 2m
Sensitivity: 100%/75%/50%/25%

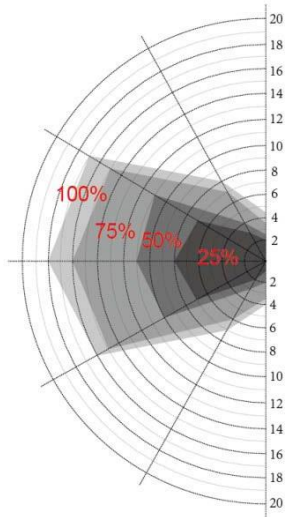

Normal moving (Speed: 1m/s)

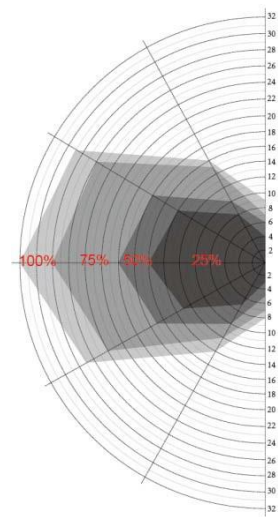

Slow moving (Speed 0.3m/s)

8. Remote Control - Halco 28050

Remote Control Setting	Button	Remarks																												
		Press the "ON/OFF" button, the light goes to constant on/off mode, sensor is disabled, Press "Reset" "Auto mode" button to quit from this mode and the sensor starts to work.																												
	Reset	Press "Reset" button, all parameters are same as setting of DIP switch or factory settings.																												
	Sensor motion	Press "Sensor motion" button, the light quits from the constant on/ off mode, and the sensor starts to work (The latest setting stays in validity)																												
	DIM Test	Press "DIM Test" button, the 1-10 V dimming works to test whether the 1-10Vdc dimming ports are connected properly. After 2s, it returns to the latest setting automatically.																												
	Dverride DH	Long press 3s, Daylight priority mode will be switched to daylight threshold mode, lux value will go back to previous one.																												
	DIM+ DIM-	Short press "DIM+/DIM-" button to Set the output lumen level, each press will will $\pm 2\%$ light level																												
	DH Mode	Long press >3s, sensor will be switched to daylight priority mode; if preset daylight value is Disable,, press DH Mode can not start daylight priority mode.																												
	Q1 Q2 Q3	<table border="1"> <thead> <tr> <th>Scene Options</th> <th>Detection Area</th> <th>Hold Time</th> <th>Stand-by period</th> <th>Stand-by dim level</th> <th>Daylight Sensor</th> <th>Induction model</th> </tr> </thead> <tbody> <tr> <td>QS1</td> <td>100%</td> <td>5min</td> <td>10min</td> <td>10%</td> <td>30Lux</td> <td>Hs</td> </tr> <tr> <td>QS2</td> <td>100%</td> <td>10min</td> <td>30min</td> <td>10%</td> <td>Disable</td> <td>Hs</td> </tr> <tr> <td>QS3</td> <td>100%</td> <td>20min</td> <td>30min</td> <td>10%</td> <td>Disable</td> <td>Hs</td> </tr> </tbody> </table>	Scene Options	Detection Area	Hold Time	Stand-by period	Stand-by dim level	Daylight Sensor	Induction model	QS1	100%	5min	10min	10%	30Lux	Hs	QS2	100%	10min	30min	10%	Disable	Hs	QS3	100%	20min	30min	10%	Disable	Hs
Scene Options	Detection Area	Hold Time	Stand-by period	Stand-by dim level	Daylight Sensor	Induction model																								
QS1	100%	5min	10min	10%	30Lux	Hs																								
QS2	100%	10min	30min	10%	Disable	Hs																								
QS3	100%	20min	30min	10%	Disable	Hs																								
	TEST 2S	Press the "TEST 2S" button can enter the test mode any time. At the mode, the sensor parameters as below: Detection Area is 100%, Hold Time is 5s, Stand-by Dim Level is 10%, Stand-by Period is 0s, daylight sensor disable. This function only for testing. Quit the mode by pressing "RESET" or any other function buttons.																												
	HS LS	Press "HS" button to set the detection area to be high sensitive. Press "LS" button to set the detection area to be low sensitive. The adjustment bases on the "Detection Area" parameter you set.																												
	Daylight Sensor	Set up daylight threshold: 5Lux/15Lux/30Lux/50Lux/100Lux/150Lux/ Disable.																												
	Stand-by period	Set up stand-by time: 0S/10S/1min/3min/5min/10min/30min/+∞																												
	Hold time	Set up hold time: 5S/30S/1min/3min/5min/10min/20min/30min																												
	Stand-by dim level	Set up stand-by dim level: 10%/20%/30%/50%																												
	Detection Area	Set up detection area: 25%/50%/75%/100%																												
	Remote Distance	Toggle button can set the remote distance of remote control and sensor.																												

9. Initialization

1) On/Off function /3-step dimming function:

After power on, the sensor automatically turns on light at 100% brightness. After 10sec, it turns off the light. During the initialization, the sensor is not able to detect movement.

2) 2-step dimming function:

After power on, the sensor automatically turns on light at 100% brightness. After 10sec, it dims the light to a low light level (set by stand-by dim level). During the initialization, the sensor is not able to detect movement.

10. Factory Setting

Detection area: 100%, Hold Time: 20min, Stand-by Period: +∞, Stand-by dim level: 50%, Daylight Sensor: Disable

11. Application Notice

- The sensor should be installed by a professional electrician. Please turn off the power before installing, wiring, changing the setting of the DIP switch.
- The sensor which installed in the plastic and glass lampshade will reduce the sensitivity. For every 3mm increase in thickness, the sensitivity will be reduced by 20%.
- The dimming performance could be different from different 0-10v drivers.
- The light sensitivity threshold is in a sunny environment, no shadow and ambient light diffuse reflection. Ambient lux level could be different in different environment, weather, climate, time-of-day and season.
- The parameters of the sensor may need to be reconfigured in different installation environments. Please refer to the following instructions or contact the manufacturer.
- This sensor is for indoor use only. It will affect the waterproof effect for outdoor use. Wind, rain, and moving objects around will cause false triggering.
- The distance between any inductive sensors should be greater than 3m.
- Do not place the sensor close to high-density objects such as metal, glass, concrete walls, etc, false triggering could happen.
- When the sensor is installed in a metal lamp, metal reflective surface, or a narrow enclosed environment, the microwave will be reflected repeatedly and cause false triggering. Please reduce the sensitivity or contact the manufacturer for technical support.
- Please ensure that there are no moving signals around the sensor, such as fan, DC motor, sewer pipe, air outlet, etc., the sensor may generate false trigger.
- You are advised to test 5 samples before mass application of sensor in a new lighting project.
- Due to continuous improvement, the contents of this instruction could be changed without prior notice